

The initial interactions underlying binocular rivalry require visual awareness

Sarah Hancock

Department of Psychology, University of York, York, UK



David Whitney

Center for Mind and Brain, UC Davis, California, USA



Timothy J. Andrews

Department of Psychology, University of York, York, UK



Current theories of binocular vision suggest that the neural processes that resolve interocular conflict do not involve a single brain region but occur at multiple stages of visual processing. Here, using an adaptation paradigm, we explore the initial mechanisms involved in selecting a stimulus for perceptual dominance during binocular rivalry. When one or both eyes briefly viewed an adapting grating stimulus prior to the presentation of the adapting grating to one eye and an orthogonal, non-adapted grating to the other eye, participants more often reported perceptual dominance of the non-adapted grating. Crowding reduced awareness of the adapting grating. On trials in which subjects were unaware of the orientation of the adaptor grating, there was no effect of the adaptor on perceived dominance during rivalry; participants were just as likely to report dominance of the adapted or non-adapted grating. This implies that the initial events in binocular rivalry involve later stages of visual processing.

Keywords: binocular, visual crowding, adaptation

Citation: Hancock, S., Whitney, D., & Andrews, T. J. (2008). The initial interactions underlying binocular rivalry require visual awareness. *Journal of Vision*, 8(1):3, 1–9, <http://journalofvision.org/8/1/3/>, doi:10.1167/8.1.3.

Introduction

Visual adaptation provides a useful tool to study the neural mechanisms of visual perception (Blakemore & Campbell, 1969; Clifford, 2002; Gibson & Radner, 1937). For example, prior viewing of a visual stimulus can reduce sensitivity to or bias perception away from the adapting stimulus. A number of studies have shown adaptation to a visual stimulus can still occur under conditions that render the adaptor invisible (Kim & Blake, 2005). For example, a stimulus that is rendered invisible due to crowding can give rise to different pattern-selective (He, Cavanagh, & Intriligator, 1996; He & MacLeod, 2001; Blake, Tadin, Sobel, Raissian, & Chong, 2006) and motion-selective aftereffects (Aghdaee, 2005; Blake et al., 2006; Rajimehr, Vaziri-Pashkam, Afraz, & Esteky, 2004; Whitney, 2005). Binocular rivalry also provides a technique for reducing awareness of an otherwise visible stimulus. Psychophysical studies have shown that the perceptual suppression that occurs during rivalry appears to have no impact on the build-up of orientation-selective (Blake & Fox, 1974; Wade & Wenderoth, 1978) and motion-selective aftereffects (Lehmkuhle & Fox, 1975; O'Shea & Crassini, 1981).

The adaptation that leads to many visual aftereffects is thought to involve early visual cortical areas such as V1 (Dragoi, Sharma, & Sur, 2000; Movshon & Lennie, 1979; Vautin & Berkley, 1977) and MT (Huk, Ress, & Heeger, 2001; Théoret, Kobayashi, Ganis, Di Capua, &

Pascual-Leone, 2002). Because the magnitude of these aftereffects is independent of the visibility of the adaptor, it has been concluded that early visual cortical areas do not contribute directly to visual awareness. However, this interpretation has been challenged recently by the finding that the strength of visual adaptation can depend on visual awareness. Blake et al. (2006) reported that the threshold-elevation aftereffect and the translational-motion aftereffect were significantly reduced during crowding and rivalry, if the stimuli were presented at lower contrast. The explanation for why previous studies failed to show this effect was due to saturation of the adaptation mechanism caused by using high contrast stimuli. The implications of these findings are that awareness of an adaptor is important for generation of these aftereffects, and early visual areas may contribute to visual awareness. It is important to note, however, that significant adaptation was still apparent even when the stimuli were suppressed from awareness. Therefore, although crowding and rivalry may cause an effective reduction in awareness, this does not imply that the adaptation mechanism is dependent on the visibility of the adapting stimulus.

The aim of the current study is to use crowding and adaptation to probe the initial processes involved in binocular rivalry. Current models of rivalry suggest that the neural processes occur at multiple stages of the visual hierarchy (Blake & Logothetis, 2002; Wilson, 2003). The visual system must first determine whether the images in the two eyes are compatible and then select one stimulus for perceptual dominance and render the other suppressed.

The initial selection for perception dominance can be influenced by a previously viewed stimulus. For example, if one or both eyes briefly view a grating stimulus prior to contour rivalry, subjects tend to report perceptual dominance of the non-adapted grating (Holmes, Hancock, & Andrews, 2006; Wolfe, 1984). In the current study, we asked whether this adaptation requires that the stimulus is visible. Using crowding, we show that the effect of an adapting stimulus on the initial selection for dominance during binocular rivalry is dependent on awareness of the adaptor. This suggests that the initial interactions underlying rivalry occur at higher stages of the processing hierarchy.

Methods

Stimuli were programmed using a ViSaGe visual stimulus generator (www.crsi.com) and were presented on a Clinton Monoray monochrome monitor (mean luminance: 9.3 cd/m²) with a frame rate of 120 Hz. Gamma correction was used to ensure that the monitor was linear over the entire luminance range used in the experiments. Subjects viewed the display in a darkened room at a distance of 1.14 m through Ferro-Electric Shutter Goggles (CRS, Rochester, England) that alternately occluded the two eyes at the same frequency as the frame rate of the monitor. When the display was alternated on successive frames, each frame was only seen by one eye with no perceptible flicker. Responses were recorded via a CT6 response box (www.crsi.com). Stimuli consisted of sine wave gratings (size: 0.75°; spatial frequency: 4 cycles per degree; contrast: 80%) presented on a neutral background. 4 subjects with normal vision took part in the experiments.

Experiment 1

This experiment used an adaptation paradigm similar to that used by Holmes et al. (2006). Figure 1 shows the experimental setup. Subjects viewed a central fixation cross for one second prior to the presentation of a grating patch to both eyes for one second. The orientation of the adaptor was either left-tilted (45 deg) or right-tilted (135 deg). This was followed by a 50-ms interstimulus interval. Next, a grating patch with the same orientation as the adaptor was presented to one eye and an orthogonal grating was presented to the other eye in the same location of visual space for 1 s. With this design, a transient onset was manifest in both eyes during rivalry. The centre of the adaptor and rivalry gratings was four degrees above fixation (Figure 1). Subjects were required to keep fixation on the central cross that remained present for the entire trial. The subject's task was to report both the

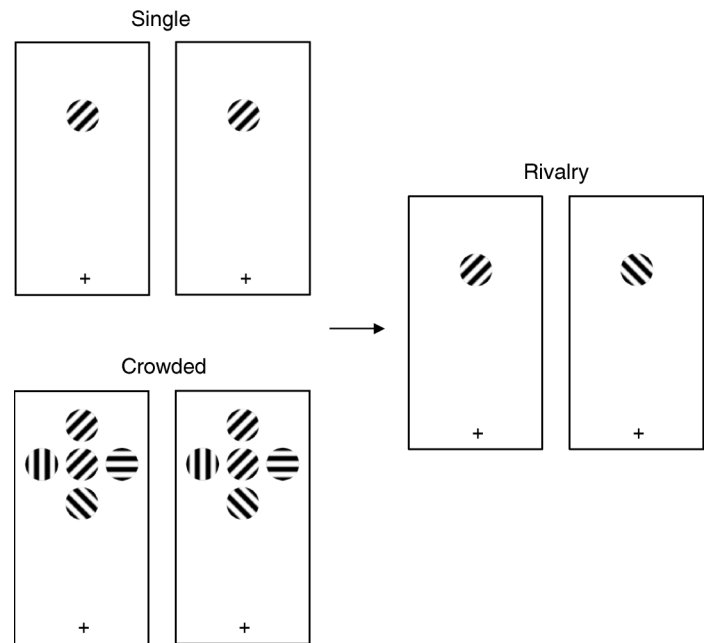

Figure 1. Stimuli used in Experiment 1 to determine the effect of a binocularly viewed adaptor grating on perceived dominance during rivalry in the presence (crowded) or absence (single) of distracter gratings.

orientation of the adaptor (right-tilted or left-tilted) and the percept during binocular rivalry (left-tilted, right-tilted, or piecemeal).

In the single condition, the adaptor was presented alone. In the crowded condition, 4 distracter gratings were presented around the adaptor. The distracter gratings were presented directly above, below, and to the left and right of the adaptor with a separation of 0.1 degrees from the adaptor. In each trial, one distracter grating was presented at each of the following 4 orientations: 0, 90, 45, and 135 degrees. All configurations of distracter position and orientation, adaptor orientation, and rivalry eye of presentation were used. Subjects performed 5 blocks of 96 trials for the single and crowded condition. Each block contained 12 repetitions of all combinations of adaptor orientation and eye of presentation of rivalry gratings in a random order. To examine the effect of crowding on adaptation, we calculated the difference in dominance of the non-adapted and adapted grating as a percentage of trials in which exclusive dominance was reported during binocular rivalry. However, it is important to note that the term adaptation typically refers to the changes in the threshold for detection rather than using competition between 2 suprathreshold stimuli.

Experiment 2

Next, we examined the influence of crowding on adaptation using the flash-suppression paradigm (Wolfe,

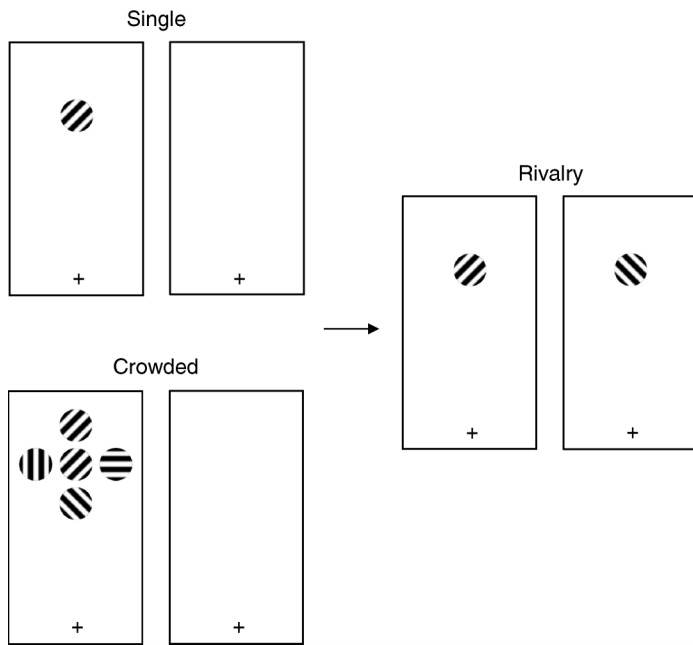

Figure 2. Stimuli used in Experiment 2 to determine the effect of a monocularly viewed adaptor grating on perceived dominance during binocular rivalry.

1984). The paradigm was identical to that used in Experiment 1, except that the adaptor grating patch was only presented in one eye. During the rivalry phase, the

adaptor grating was viewed in the adapted eye and an orthogonal grating was presented to the other eye. Again subjects were required to report the orientation of the adaptor grating and the dominant percept in rivalry. The adaptor could be presented in a single or crowded condition (Figure 2). Subjects completed 5 blocks of 96 trials for each condition. Again, all combinations of adaptor orientation and eye of presentation (and distracter configuration in the crowded conditions) were presented in a random order.

Experiment 3

In Experiment 3, we determined whether the effect of crowding was a result of attenuation in the awareness of the stimulus or resulted from spatial summation of the adaptor and distracter gratings. The paradigm was similar to that used in Experiments 1 and 2. In this experiment, all the distracter gratings had the same orientation. There were two main conditions (Figure 3): In the first condition, an adaptor grating was presented that was collinear with the distracter gratings (adaptor present); in the second condition, the adaptor was absent (adaptor absent). During the adaptation phase, stimuli were shown to either one or both eyes. Subjects completed 5 separate blocks for each condition and each paradigm. In the adaptor-present condition, subjects made both the adaptor

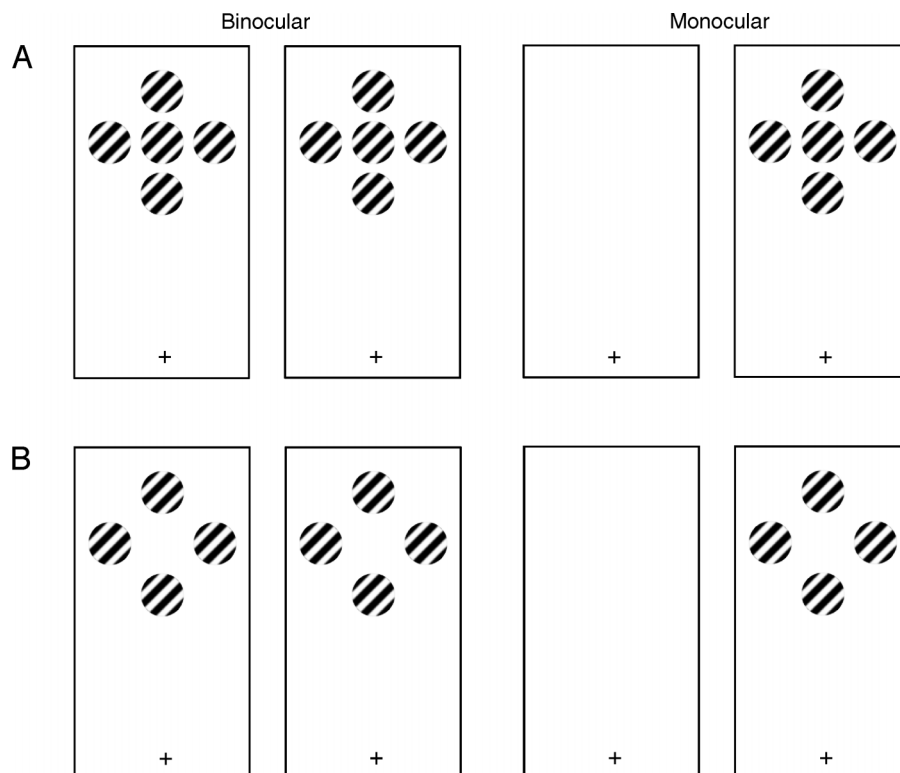

Figure 3. Stimuli used in Experiment 3 to determine the effect of the distracter gratings on perceptual dominance during binocular rivalry.

and the rivalry responses. In the adaptor-absent condition, only the rivalry response was made.

Experiment 4

In this experiment, we investigated the effect of contrast on adaptation. The procedure and stimuli were the same as those for [Experiment 1](#). In both the single and crowded conditions, the adaptor was presented to both eyes with a variable contrast. As in the other paradigms, the distracter and rivalry grating patches had a fixed contrast of 80%. The contrast and orientation of the adaptor, the eye of presentation during rivalry, and the configuration of the distracter gratings in the crowded condition were all randomized within blocks. Subjects performed the single and crowded conditions in separate blocks.

Results

Experiment 1

[Figure 4A](#) shows the percentage correct in discriminating the adaptor in the single and crowded conditions. Accuracy was significantly greater in the single (95.0%; $d' = 3.3$) compared to the crowded (58.2%; $d' = 0.42$) condition ($t(3) = 8.33$, $p < .01$). Next, we examined the effect of the adaptor on perception during binocular rivalry. In the single condition, we found that there was a significant effect of the adaptor grating on perceptual rivalry ($t(3) = 12.84$, $p < .001$). Perceptual dominance of the non-adapted grating ($65.4 \pm 14.0\%$) was reported more often than the adapted grating ($7.9 \pm 4.3\%$) during binocular rivalry. Crowding significantly reduced this adaptation effect ($t(3) = 15.10$, $p < .001$), with participants more likely to report perceptual dominance of the adapted grating ($27.0 \pm 5.5\%$) and less likely to report the non-adapted ($56.8 \pm 9.1\%$) than in the single condition.

[Figure 4B](#) shows the effect of adaptation in the single and crowding conditions, by taking the difference in dominance of the non-adapted and adapted grating on trials in which exclusive dominance was reported during rivalry. Trials in the crowded condition were separated according to whether participants made correct or incorrect judgments of the orientation of the adaptor grating (see [Figure 4B](#)). We found that there was significant adaptation when the orientation of the adaptor was reported correctly ($t(3) = 3.61$, $p < .05$), but there was no adaptation when the orientation of the adaptor was reported incorrectly ($t(3) = 0.56$, $p = .61$). Piecemeal responses were made on around 20% of trials (single: $26.7 \pm 15.3\%$; crowded: $16.2 \pm 12.3\%$). There was no significant difference in the amount of piecemeal responses between conditions ($t(3) = 2.41$, $p = .10$).

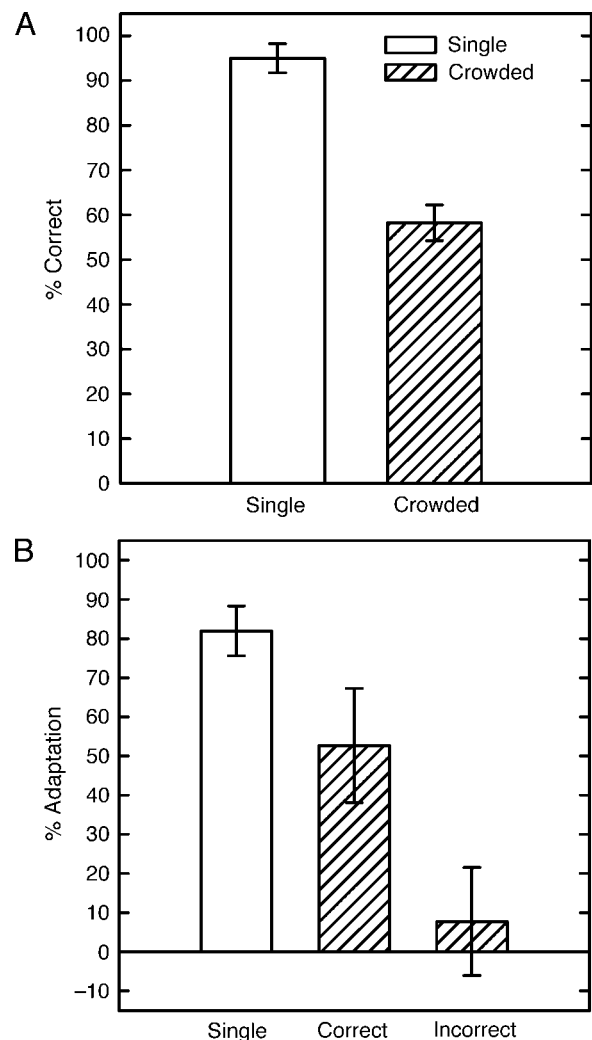

Figure 4. [Experiment 1](#). (A) Percent of trials in which participants correctly reported the orientation of the adaptor grating in the single and crowded conditions. (B) Percent adaptation is the difference in perceptual dominance of the adapted and non-adapted grating during binocular rivalry. In the crowded condition, percent adaptation was calculated separately for trials in which subjects reported the adaptor grating correctly and incorrectly. Error bars represent ± 1 SEM.

Experiment 2

Next, we explored how crowding affected adaptation in the flash-suppression paradigm (Wolfe, 1984). Accuracy was significantly greater in the single (99.1%; $d' = 4.8$) compared to the crowded (61.9%; $d' = 0.62$) condition ($t(3) = 13.99$, $p < .001$, [Figure 5A](#)). When the adaptor grating was presented in isolation, there was a clear bias toward reporting the non-adapted ($73.3 \pm 3.8\%$) rather than the adapted ($3.8 \pm 3.2\%$) grating patch during binocular rivalry. Crowding significantly reduced the effect of adaptation ($t(3) = 4.22$, $p < .05$) with participants more likely to report perceptual dominance of the adapted

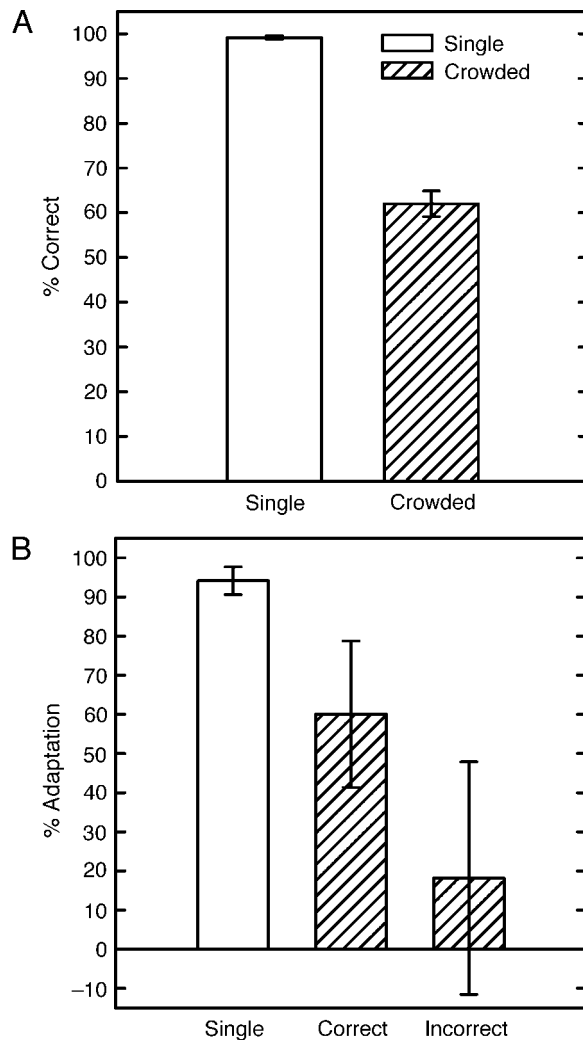

Figure 5. **Experiment 2.** (A) Percent of trials in which participants correctly reported the orientation of the adaptor grating in the single and crowded conditions. (B) Percent adaptation in the single and crowded condition. In the crowded condition, percent adaptation was calculated separately for trials in which the adaptor grating was reported either correctly or incorrectly. Error bars represent ± 1 SEM.

grating ($23.2 \pm 7.5\%$) and less likely to report the non-adapted grating ($60.7 \pm 10.9\%$) than in the single condition.

Figure 5B shows the adaptation effect for trials in which exclusive dominance was reported during binocular rivalry. We compared adaptation for trials when the adaptor response was correct and when it was incorrect. No significant adaptation was found for incorrect trials ($t(3) = 0.61$, $p = .58$); however, there was a significant adaptation effect for correct trials ($t(3) = 3.21$, $p < .05$). Piecemeal responses were made on around 20% of trials (single: $22.8 \pm 14.8\%$; crowded: $16.1 \pm 12.6\%$). There was no significant difference in the amount of piecemeal responses between conditions ($t(3) = 2.14$, $p = .12$).

Experiment 3

The aim of this experiment was to determine whether the effect of crowding was due to a lack of awareness of the adaptor or spatial summation of the distracter gratings. We compared the effect of the adaptor when it was presented with distracters that had the same orientation (left- or right-tilted). The adaptor grating always had the same orientation as the distracters. In half the trials, the adaptor grating was present and in the remaining trials it was absent. First, we compared adaptation when gratings were presented to one or both eyes during the adaptor phase of the trial (see Figure 3).

Figure 6A shows there was significant adaptation (S1: $t(4) = 5.52$, $p < .001$; S2: $t(4) = 6.70$, $p < .005$) when the adaptor grating was present, but no significant adaptation

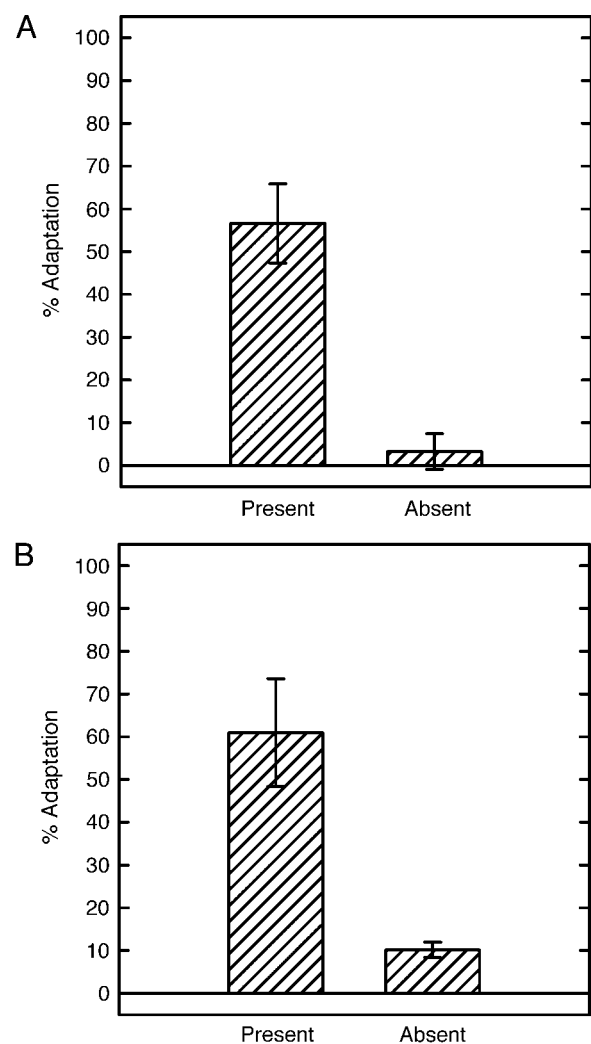

Figure 6. **Experiment 3.** The effect of the distracter gratings on adaptation to a (A) binocular or (B) monocular adaptor. During the adaptation phase, all distracter gratings had the same orientation. On some trials, an adaptor grating with the same orientation as the distracters was present and on other trials it was absent. Error bars represent ± 1 SEM.

when the adaptor was absent (S1: $t(4) = 2.35$, $p = .08$; S2: $t(4) = -.12$, $p = .91$) for both subjects tested. Figure 6B shows the effect of adaptation when gratings were viewed with one eye prior to rivalry. Significant adaptation was reported when the adaptor grating was present (S1: $t(4) = 2.87$, $p < .05$; S2: $t(4) = 25.66$, $p < .001$), but not when it was absent (S1: $t(4) = 2.15$, $p = .10$; S2: $t(4) = 1.38$, $p = .24$). Overall, it would appear that adaptation cannot be influenced directly by the surrounding gratings.

Experiment 4

In this experiment, we investigated the effect of varying the contrast of the adapting stimulus (Figure 7). In the single condition, adaptation increased significantly with contrast for both subjects tested (S1: $F(10,290) = 8.47$, $p < .001$; S2: $F(10, 110) = 4.06$, $p < .001$). Significant adaptation was only apparent for contrasts greater than 20–30% in the single condition. Adaptation was not affected by adaptor contrast in the crowded condition (S1: $F(10,70) = 1.00$, $p = .45$; S2: $F(10, 50) = 1.25$, $p = .29$). There was also no difference between trials in which subjects judged the orientation of the adaptor either correctly or incorrectly. By comparing the effect of contrast on adaptation in the different conditions, these results show the effect of crowding is equivalent to reducing the effective contrast of the adaptor. However, given that we do not find significant adaptation in the crowding condition, it is not clear whether this reduction in effective contrast involves a subtractive or divisive mechanism (see Pearson & Clifford, 2005).

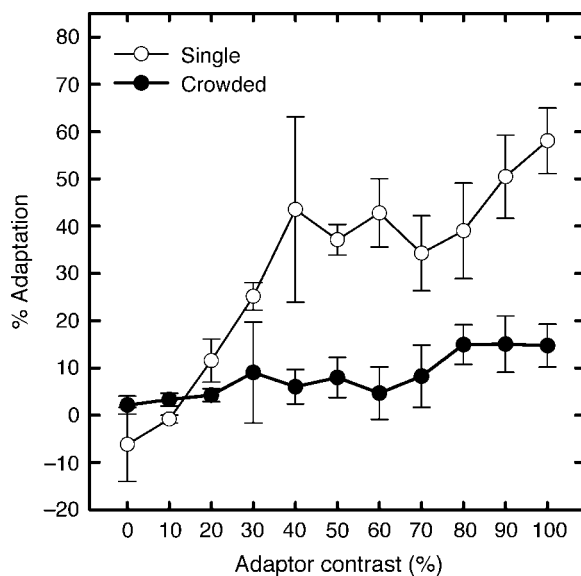

Figure 7. Experiment 4. Percent adaptation in the single and crowded conditions for different adaptor contrasts. Error bars represent ± 1 SEM.

Discussion

This study examined the effect of visual crowding on adaptation prior to the onset of binocular rivalry. The aim was to explore the neural mechanisms that underlie the induction of binocular rivalry. We used a paradigm in which one or both eyes briefly viewed an adapting grating stimulus prior to the presentation of the adapting grating to one eye and an orthogonal, non-adapted grating to the other eye. In normal viewing, participants reported perceptual dominance of the non-adapted grating more often than the adapted grating during rivalry. Crowding reduced this adaptation effect with participants more likely to report perceptual dominance of the adaptor in the crowding condition than in the single condition. On trials in which the orientation of the adapting grating was incorrectly reported, there was no adaptation. That is, participants were just as likely to report dominance of the adapted or non-adapted grating during binocular rivalry.

One possible explanation of these findings is that during crowding the visual system pools orientation information from the adaptor and distracter gratings and adapts to the average orientation. This could explain a reduction in adaptation during crowding. Indeed, previous studies have shown that a grating that is rendered invisible due to crowding can continue to contribute toward the overall perception of orientation (Parkes, Lund, Angelucci, Solomon, & Morgan, 2001). To control for this possibility, we used a stimulus in which all distracter gratings had the same orientation during the adaptation phase of the trial. On some trials, an adaptor grating was present with the same orientation as the distracters and on other trials the adaptor grating was absent. The results clearly show that adaptation was dependent on the presence of the adaptor. This shows that the effect of crowding in this paradigm was due to interference with the awareness of the adaptor rather than spatial pooling of orientation information.

Previous studies have shown that a grating stimulus rendered invisible due to crowding or binocular rivalry remains as effective in producing orientation-selective visual aftereffects as when it is visible (Blake & Fox, 1974; He et al., 1996; Rajimehr, Montaser-Kouhsari, & Afraz, 2003; Wade & Wenderoth, 1978). In contrast, adaptation to complex motion (Wiesenfelder & Blake, 1990) and faces (Moradi, Koch, & Shimojo, 2005) has been shown to be completely eliminated in the absence of awareness. The reduction in the orientation-selective adaptation in this study suggests that the neural origins of this effect differ from those that lead to conventional orientation-selective visual aftereffects. However, Blake et al. (2006) recently reported that the strength of orientation- and motion-selective aftereffects can be reduced during crowding, if the stimuli are presented at lower contrast thus avoiding saturation effects. In this study, we found that crowding reduced the effect of adaptation, even when the

stimulus was presented at a high contrast. Again, this suggests that different neural events underlie the aftereffect in this study.

When faced with two incompatible stimuli, the visual system must select one stimulus for perceptual dominance. The implication of these findings is that the initial selection for dominance during binocular rivalry involves later stages of visual processing. This would also be consistent with the knowledge that identical physical stimuli can be induced to rival if they are made to appear perceptually different by the context in which they are viewed (Andrews & Lotto, 2004; Wallach & Adams, 1954). Similarly, Watson, Pearson, and Clifford (2004) used point-light walkers to demonstrate global pattern rivalry even when the constituent elements of the point-light walkers did not occupy corresponding locations. Presumably, the neural processes involved in registering these types of rivalry are likely to involve later stages of processing. However, these results contrast with a study by Carlson and He (2004) who reported that rivalry only occurs, if local elements are incompatible across the two eyes; an interocular difference in global form was insufficient to instigate perceptual rivalry. It is not clear why these studies have come to different conclusions, but it is possible that the resolution of this issue might depend on the degree to which local and global processes relate to early and late stages of processing in the visual system.

Physiological studies have not concurred on the neural mechanism underlying binocular rivalry. Single neuron investigations show some areas of visual cortex modulate their activity during binocular rivalry, but others do not. In early visual areas, such as V1 and V2, only a small proportion of neurons display fluctuations in activity that co-vary with shifts in perceptual dominance (Leopold & Logothetis, 1996; Sengpiel, Blakemore, & Harrad, 1995). In contrast, the vast majority of neurons in the inferotemporal lobe show changes in activity that correspond to changes in perception during rivalry (Sheinberg & Logothetis, 1997). Although fMRI studies have also demonstrated that the neural competition underlying binocular rivalry is resolved in higher visual areas (Tong, Nakayama, Vaughan, & Kanwisher, 1998), more recent studies have found that the interactions involving binocular rivalry can also occur at early stages of visual processing, such as V1 (Lee, Blake, & Heeger, 2005; Polonsky, Blake, Braun, & Heeger, 2000; Tong & Engel, 2001) and even the LGN (Haynes & Rees, 2005; Wunderlich, Schneider, & Kastner, 2005).

An emerging consensus on this disparate neurophysiological evidence has been proposed by models of rivalry in which the neural processes do not reduce to a single brain region but occur at multiple stages along the processing hierarchy (Alais & Blake, 2005; Blake & Logothetis, 2002; Pearson & Clifford, 2005; Tong, Meng, & Blake, 2006; Wilson, 2003). These models have been developed in part to explain the variety of evidence that

indicates either low-level or high-level interactions during binocular rivalry. However, these models are not explicit on the sequence of processing stages. For example, evidence for low-level effects of rivalry could represent feed-back from high-level areas, whereas high-level effects could be the feed-forward result of earlier stages of processing. Our results show that the initial interactions underlying binocular rivalry require visual awareness and thus could involve later stages of visual processing.

Acknowledgments

This research was supported by an EPSRC grant to TJA.

Commercial relationships: none.

Corresponding author: Tim Andrews.

Email: t.andrews@psych.york.ac.uk.

Address: Department of Psychology, University of York, York, YO10 5DD, UK.

References

- Aghdaee, S. M. (2005). Adaptation to spiral motion in crowding condition. *Perception*, *34*, 155–162. [[PubMed](#)]
- Alais, D., & Blake, R. (2005). *Binocular rivalry*. Cambridge, MA: MIT.
- Andrews, T. J., & Lotto, R. B. (2004). Fusion and rivalry are dependent on the perceptual meaning of visual stimuli. *Current Biology*, *14*, 418–423. [[PubMed](#)] [[Article](#)]
- Blake, R., & Fox, R. (1974). Adaptation to invisible gratings and the site of binocular rivalry suppression. *Nature*, *249*, 488–490. [[PubMed](#)]
- Blake, R., & Logothetis, N. K. (2002). Visual competition. *Nature Reviews, Neuroscience*, *3*, 13–21. [[PubMed](#)]
- Blake, R., Tadin, D., Sobel, K. V., Raissian, T. A., & Chong, S. C. (2006). Strength of early visual adaptation depends on visual awareness. *Proceedings of the National Academy of Sciences of the United States of America*, *103*, 4783–4788. [[PubMed](#)] [[Article](#)]
- Blakemore, C., & Campbell, F. W. (1969). On the existence of neurons in the human visual system selectively sensitive to the orientation and size of retinal images. *The Journal of Physiology*, *203*, 237–260. [[PubMed](#)] [[Article](#)]

- Carlson, T. A., & He, S. (2004). Competing global representations fail to initiate binocular rivalry. *Neuron*, *43*, 907–914. [PubMed] [Article]
- Clifford, C. W. (2002). Perceptual adaptation: Motion parallels orientation. *Trends in Cognitive Sciences*, *6*, 136–143. [PubMed]
- Dragoi, V., Sharma, J., & Sur, M. (2000). Adaptation-induced plasticity of orientation tuning in adult visual cortex. *Neuron*, *28*, 287–298. [PubMed] [Article]
- Gibson, J. J., & Radner, M. (1937). Adaptation, after-effect and contrast in the perception of tilted lines. *Journal of Experimental Psychology*, *20*, 453–467.
- Haynes, J. D., Deichmann, R., & Rees, G. (2005). Eye-specific effects of binocular rivalry in the human lateral geniculate nucleus. *Nature*, *438*, 496–499. [PubMed] [Article]
- He, S., Cavanagh, P., & Intriligator, J. (1996). Attentional resolution and the locus of visual awareness. *Nature*, *383*, 334–337. [PubMed]
- He, S., & MacLeod, D. I. (2001). Orientation-selective adaptation and tilt after-effect from invisible patterns. *Nature*, *411*, 473–476. [PubMed]
- Holmes, D. J., Hancock, S., & Andrews, T. J. (2006). Independent binocular integration for form and colour. *Vision Research*, *46*, 665–677. [PubMed]
- Huk, A. C., Ress, D., & Heeger, D. J. (2001). Neuronal basis of the motion aftereffect reconsidered. *Neuron*, *32*, 161–172. [PubMed] [Article]
- Kim, C. Y., & Blake, R. (2005). Psychophysical magic: Rendering the visible ‘invisible.’ *Trends in Cognitive Sciences*, *9*, 381–388. [PubMed]
- Lee, S. H., Blake, R., & Heeger, D. J. (2005). Traveling waves of activity in primary visual cortex during binocular rivalry. *Nature Neuroscience*, *8*, 22–23. [PubMed] [Article]
- Lehmkuhle, S. W., & Fox, R. (1975). Effect of binocular rivalry suppression on the motion aftereffect. *Vision Research*, *15*, 855–859. [PubMed]
- Leopold, D. A., & Logothetis, N. K. (1996). Activity changes in early visual cortex reflect monkeys’ percepts during binocular rivalry. *Nature*, *379*, 549–553. [PubMed]
- Moradi, F., Koch, C., & Shimojo, S. (2005). Face adaptation depends on seeing the face. *Neuron*, *45*, 169–175. [PubMed] [Article]
- Movshon, J. A., & Lennie, P. (1979). Pattern-selective adaptation in visual cortical neurones. *Nature*, *278*, 850–852. [PubMed]
- O’Shea, R. P., & Crassini, B. (1981). Interocular transfer of the motion after-effect is not reduced by binocular rivalry. *Vision Research*, *21*, 801–804. [PubMed]
- Pearson, J., & Clifford, C. W. (2005). Suppressed patterns alter vision during binocular rivalry. *Current Biology*, *15*, 2142–2148. [PubMed] [Article]
- Polonsky, A., Blake, R., Braun, J., & Heeger, D. (2000). Neuronal activity in human primary visual cortex correlates with perception during binocular rivalry. *Nature Neuroscience*, *3*, 1153–1159. [PubMed] [Article]
- Parkes, L., Lund, J., Angelucci, A., Solomon, J. A., & Morgan, M. (2001). Compulsory averaging of crowded orientation signals in human vision. *Nature Neuroscience*, *4*, 739–744. [PubMed] [Article]
- Rajimehr, R., Montaser-Kouhsari, L., & Afraz, S. R. (2003). Orientation-selective adaptation to crowded illusory lines. *Perception*, *32*, 1199–1210. [PubMed]
- Rajimehr, R., Vaziri-Pashkam, M., Afraz, S. R., & Esteky, H. (2004). Adaptation to apparent motion in crowding condition. *Vision Research*, *44*, 925–931. [PubMed]
- Sengpiel, F., Blakemore, C., & Harrad, R. (1995). Interocular suppression in the primary visual cortex: A possible neural basis of binocular rivalry. *Vision Research*, *35*, 179–195. [PubMed]
- Sheinberg, D. L., & Logothetis, N. K. (1997). The role of temporal cortical areas in perceptual organization. *Proceedings of the National Academy of Sciences of the United States of America*, *94*, 3408–3413. [PubMed] [Article]
- Tong, F., Nakayama, K., Vaughan, T., & Kanwisher, N. (1998). Binocular rivalry and visual awareness in human extrastriate cortex. *Neuron*, *21*, 753–759. [PubMed] [Article]
- Tong, F., & Engel, S. A. (2001). Interocular rivalry revealed in the human cortical blind-spot representation. *Nature*, *411*, 195–199. [PubMed]
- Tong, F., Meng, M., & Blake, R. (2006). Neural bases of binocular rivalry. *Trends in Cognitive Sciences*, *10*, 502–511. [PubMed]
- Théoret, H., Kobayashi, M., Ganis, G., Di Capua, P., & Pascual-Leone, A. (2002). Repetitive transcranial magnetic stimulation of human area MT/V5 disrupts perception and storage of the motion after effect. *Neuropsychologia*, *40*, 2280–2287. [PubMed]
- Vautin, R. G., & Berkley, M. A. (1977). Responses of single cells in cat visual cortex to prolonged stimulus movement: Neural correlates of visual aftereffects. *Journal of Neurophysiology*, *40*, 1051–1065. [PubMed]
- Wade, N. J., & Wenderoth, P. (1978). The influence of colour and contour rivalry on the magnitude of the tilt after-effect. *Vision Research*, *18*, 827–835. [PubMed]
- Watson, T. L., Pearson, J., & Clifford, C. W. (2004). Perceptual grouping of biological motion promotes

- binocular rivalry. *Current Biology*, *14*, 1670–1674. [[PubMed](#)] [[Article](#)]
- Wallach, H., & Adams, P. A. (1954). Binocular rivalry of achromatic colors. *American Journal of Psychology*, *67*, 513–516. [[PubMed](#)]
- Whitney, D. (2005). Motion distorts perceived position without awareness of motion. *Current Biology*, *15*, R324–R326. [[PubMed](#)] [[Article](#)]
- Wiesenfelder, H., & Blake, R. (1990). The neural site of binocular rivalry relative to the analysis of motion in the human visual system. *Journal of Neuroscience*, *10*, 3880–3888. [[PubMed](#)] [[Article](#)]
- Wilson, H. R. (2003). Computational evidence for a rivalry hierarchy in vision. *Proceedings of the National Academy of Sciences of the United States of America*, *100*, 14499–14503. [[PubMed](#)] [[Article](#)]
- Wolfe, J. M. (1984). Reversing ocular dominance and suppression in a single flash. *Vision Research*, *24*, 471–478. [[PubMed](#)]
- Wunderlich, K., Schneider, K. A., & Kastner, S. (2005). Neural correlates of binocular rivalry in the human lateral geniculate nucleus. *Nature Neuroscience*, *8*, 1595–1602. [[PubMed](#)] [[Article](#)]